



Manhole reconstruction

■ General information

In our manhole-system the concrete rings (3) are raised up with rubber buffers (4). Also a maintenance cover (2) hangs free because of an adjustment device (1) and brings it in position.

Now the complete manhole neck can be covered and grouted with the help of an inflatable shutter (6) and with the Ergelit grouting mortar (5). The area around the manhole can be, if necessary, adjusted with fluid asphalt (7).

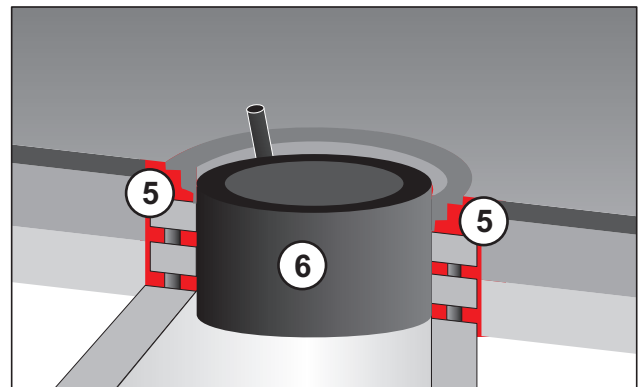
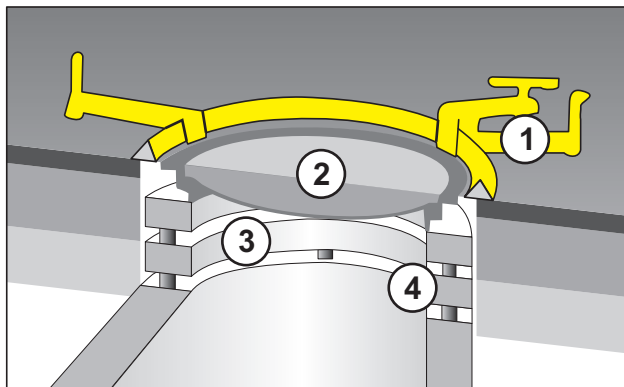

1. Adjustment device

Leveling of covers without sinking down

2. Maintenance covers

class D400; height = 10 cm; different types

3. Concrete rings

Especially for manhole reconstruction
heights: 4 cm, 6 cm, 8 cm, 10 cm

The outer diameter is smaller than the manhole frame.

4. Rubber buffer

available in heights 2 cm and 4 cm;
package unit = 50 pieces, also possible per meter

5. Grouting mortar

Superfix 10 or Superfix 35 F
(Superfix 35 F is steel fiber reinforced)

6. Inflatable shutters

For grouting with grouting mortar included hopper

7. Leveling compounds

For the leveling of manholes

PE grouting bucket



handmixer CX10